

Special extruder BGEMH 40N

(<http://rozrobkinauchni.vsocorp.org/>). E-mail: kbgarmasch@ukr.net

mob. tel. +38 095 466 23 89; +38 096 074 06 49

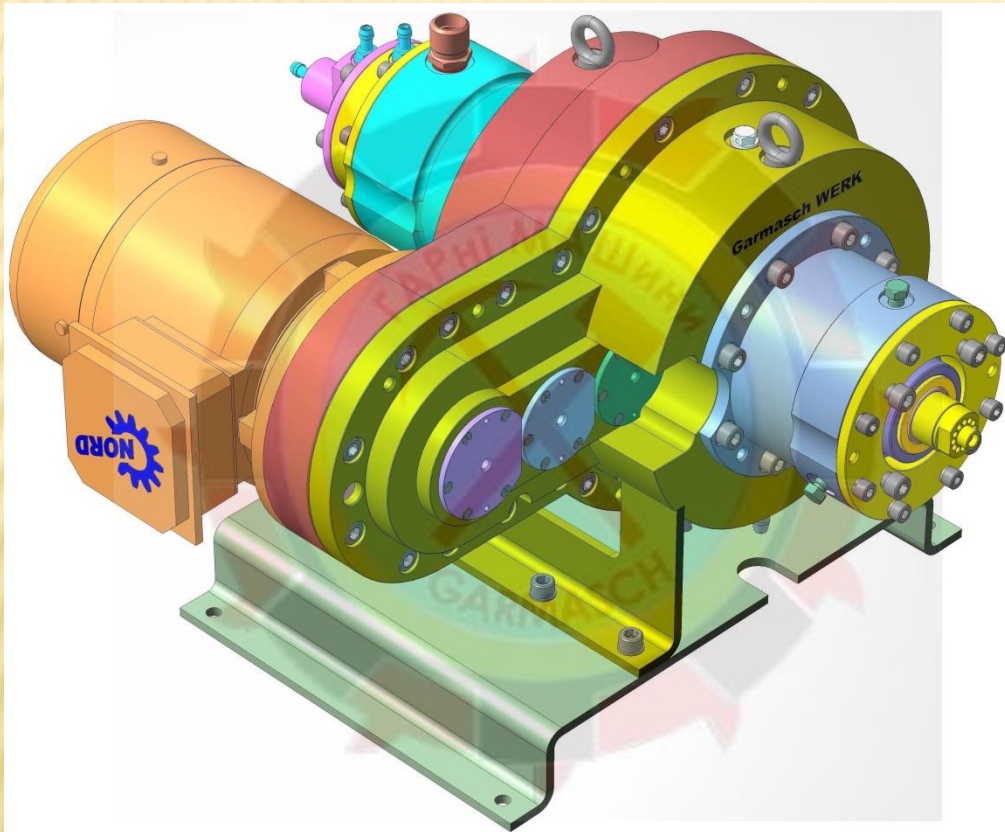

SPECIAL EXTRUDER BGEMH 40N

Special molding head for the production of artificial protein shell of caliber 40. This device is similar to the scheme of the German engineering office of Dr. Dorstewitz.

The peculiarity of the device is the ability to work on the classical scheme used at the Ukrainian enterprise LLC «Belkozin», as well as the radial supply of collagen protein substance. An additional feature of the device is the use of classic end seals of the Polish manufacturer ANGA. Also the unit is designed in a monoblock and has the ability to work with ammonia. Details for interested parties.

You can order a special extruder for the formation of an artificial protein shell by these phones or e-mail.

E-mail: kbgarmasch@ukr.net

Contact phone numbers:

(+38096) – 074 – 06 — 49

(+38095) – 466 – 23 — 89

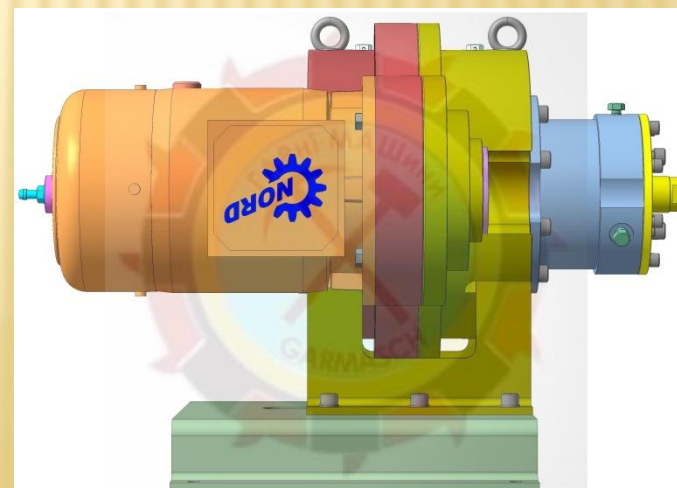
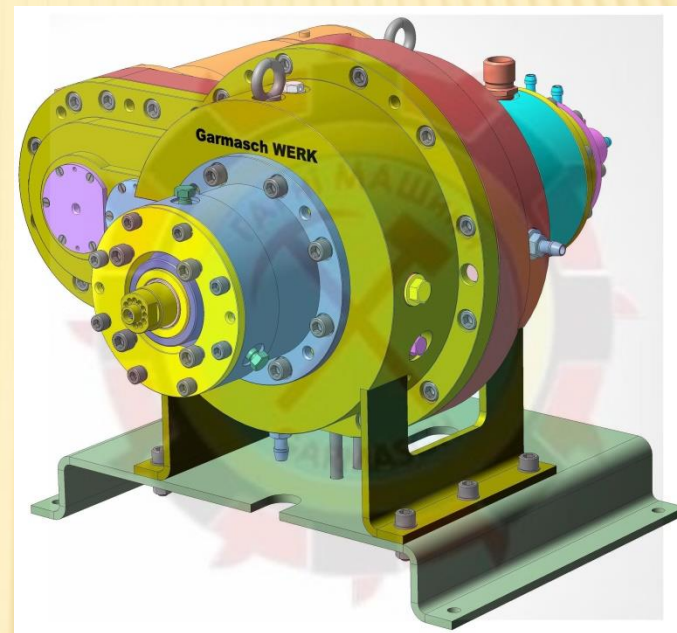

SPECIAL EXTRUDER BGEMH 40N

Caliber of the formed artificial protein shell, mm	40
The number of versions of the extruder	9
Extruder type	Rotary-toothed with a fixed shaft
The size of the gap in the area of weaving of the protein shell, mm	0,5
The ratio of the diameters of the rotor and the fixed shaft in the area of weaving the shell, mm/mm	$\text{Ø}40\text{H}10/\text{Ø}39\text{h}10$
The size of the slit of the calibration die, mm	$0,525\pm 0,01$ $0,55\pm 0,01$ $0,57\pm 0,01$
Power of the driving electric motor, kW	1,5
Mains voltage, V	230/400
Power supply voltage frequency, Hz	50
Unit weight, kg	149

